

Functionality

- The **GKD Ball Injector**, also known as a "**Ball Gun**" or a "**Ball Sealer**", originated in the late 1970's in response to requests from some of the leading well stimulation companies in Western Canada. The GKD Ball Injector and its predecessors have been successfully deployed in oil fields around the world since the early 1980's.
- The GKD Ball Injector is used to inject balls together with a pressurized acid solution (Fracture Acidizing or Matrix Acidizing) into the well. The balls are carried down to the perforations by the acid at the rate that the acid is being pumped. The balls follow the flow towards the open perforations until they seal against the open perforations, at which point the acid and an increased pressure is applied against the perforations that are not open or not fully open. This reaction opens more

perforations to the acid and repairs well bore damage - Matrix Acidizing. At higher pressures Fracture Acidizing is used to enlarge the effective wellbore. In both cases, the result is targeted fluid control, minimized fluid loss, reduced skin damage and improved flowback. Once the acidizing process is completed, the injected balls float to the top of the well if positively buoyant, sink to the bottom if negatively buoyant, or dissolve if biodegradable.

Operation

The balls can be injected by manually turning the Ball Injector's vane shaft with the supplied hand crank, thereby releasing balls into the pressurized stream of acidic solution. However, because of the dangers involved in working with large volumes of high strength acid at high pressures, most service companies use the GKD Ball Injector with the remote controlled Motor Drive Package.

Main Body Specifications

- Standard base configurations: Fig. 1502, Fig. 1002 and Fig. 602 in 2", 3" and 4" sizes, optional sizes are available and detachable wing nuts are included
- Standard equipment: Lifting Cap, Carrying Handle, Hand Crank and Spanner, Operating Service Manual and Documentation Package consisting of hydrostatic pressure test graph and material certifications for all critical components

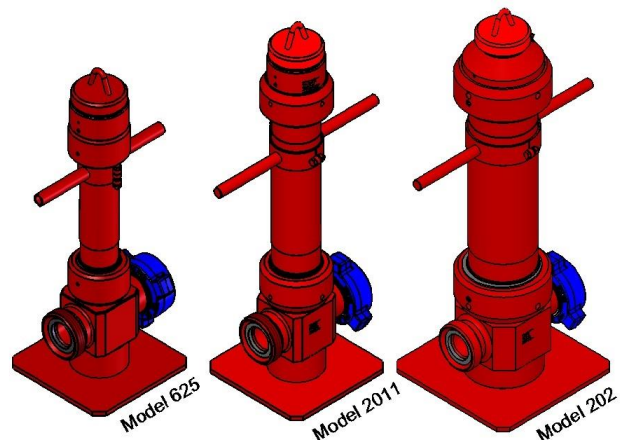
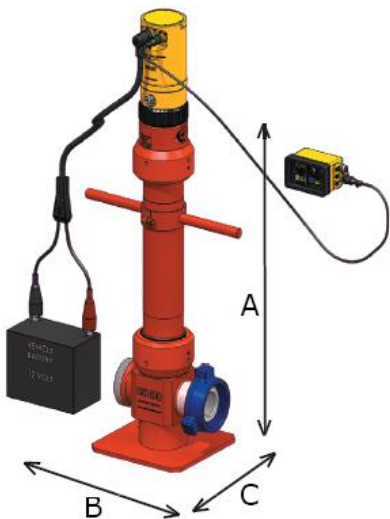

	Model 625	Model 2011	Model 202
Ball capacity	200 balls 5/8" diameter	200 balls 7/8" diameter	150 balls 1-1/4" diameter
Working pressure	15,000 PSI cwp ⁽¹⁾	15,000 PSI cwp ⁽¹⁾	15,000 PSI cwp ⁽¹⁾
Working temperature	-4°F to +140°F (-20°C to +60°C)	-4°F to +140°F (-20°C to +60°C)	-4°F to +140°F (-20°C to +60°C)
Hand crank torque	2-4 lb-ft @ 15,000 PSI	2-4 lb-ft @ 15,000 PSI	18-22 lb-ft @ 15,000 PSI
Body dimensions ⁽²⁾	A x B x C 35" x 14" x 14" (889 x 356 x 356 mm)	A x B x C 43-7/8" x 14" x 14" (1114 x 356 x 356 mm)	A x B x C 45-1/2" x 17" x 17" (1156 x 432 x 432 mm)
Shipping weight ⁽²⁾	243 lb (110 kg)	300 lb (136kg)	500 lb (227 kg)

Notes: ⁽¹⁾ maximum cold working pressure limited to lowest working pressure of base connections, ⁽²⁾ body dimensions and weights based on 3" Fig. 1502 base with Platform and Lifting Cap installed.



Includes: Motor Drive, 20' (6m) long Power Supply Cable, Remote Control, 100' (30.5m) long Remote Control Cable (200' (61m) optional), Operating Manual and custom fitted heavy duty Carrying Case

Remote Control

- Used to monitor and control GKD Ball Injector Motor Drive
- Remote Control specifications:
 - Automatic and manual modes of operation
 - Injection speed adjustment from 0.1 to 100.0 balls per minute in automatic mode, maximum injection speed 240 to 260 balls per minute in manual mode
 - Two digital backlit displays provide real-time information on injection speed (in automatic mode only) and quantity of balls discharged
 - Overload injection alarm indicator light (LED) with reverse button and reset switch
- Solid state power turn-on and totalizer-reset function
- Remote control enclosure made of anodized aluminium with clear silicon face plate cover for splash protection
- Utilizes single printed circuit board populated with high quality components for rugged long-term use
- Over-current protected with 3/4 AMP fuse
- Current consumption: 0.5 AMP max. @12 V DC
- Working temperature range of -4°F to +140°F (-20°C to +60°C)
- Dimensions: 6-3/4" long x 3-3/4" high x 4-3/4" deep (171 mm x 95 mm x 121 mm), weight 2 lb (0.95 kg)

Motor Drive Specification

- 0.6 HP 12 V DC motor coupled with planetary gear system provides 25 lb-ft of torque at 32 rpm (approximate), connected to 12V vehicle battery via heavy duty 20' (6 m) Power Cable utilizing military spec environmental resistant connectors
- Motor installed in an anodized aluminium housing with plated or stainless steel parts throughout for corrosion resistance – manual pressure equalizing valve enables pressure or vacuum relief if required.
- Anti-vibration spring-loaded nut with safety latch assembly prevents accidental loosening of motor drive from the main body during operation
- Built-in automatically re-settable 50 AMP over-current protection
- Dimensions: 12-3/8" long x 6-3/8" diameter (314 mm x 162 mm), weight 25 lb (11.3 kg)
- Working temperature range -40°F to +160°F (-40°C to +70°C)
- Motor current consumption: 38-42 AMP @15,000 PSI (fully charged 12V vehicle battery used)
- Maximum injection rate at 15,000 PSI; 240-260 balls/minute (Remote control set to manual mode)

